

EM1820 - Evaluation Module for TGS1820

Description:

This module facilitates evaluation of the characteristics of the acetone gas sensor TGS1820.*1

The sensor sensitivity (ΔV_{OUT}) is obtained by calculating the difference between the voltage output in a clean atmosphere and the voltage output in gas.*2

*1 Please refer to *Product Information for TGS1820* for sensor characteristics.

*2 This module will output the response of the TGS1820 sensor as a voltage change. Temperature compensation for sensor output is not a feature provided by this module.

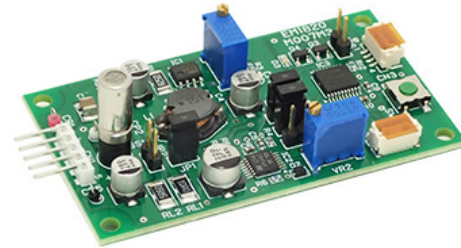

* Sensor not included

Dimensions:

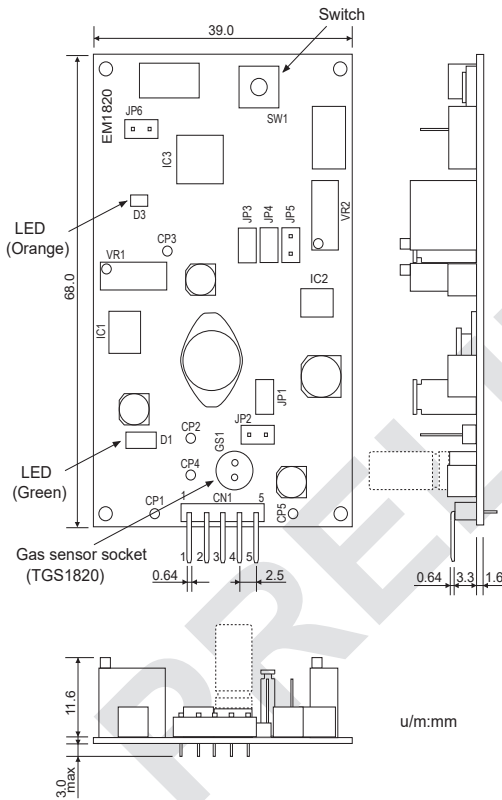

* The sensor is to be put in the sensor socket as shown in the above photo.

* Suggested female connectors mating to the 5 pin connector (JST MB5P-90S):

JST XHP-5P or JST 05JQ-BT

Circuit Diagram:

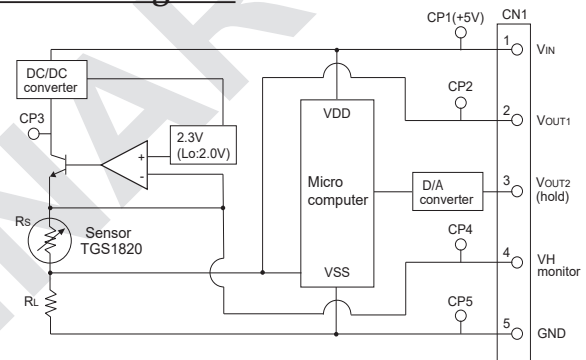

Pin Connections:

Pin No.	Name	Description
1	VIN	Input voltage 4.9~5.1V DC
2	VOUT1	Output voltage(VRL) (continuous)
3	VOUT2	Output voltage(VRL) Hold value*
4	VH monitor	Sensor applied voltage(VH) Monitor
5	GND	Ground

* Hold Value: Under Hi/Lo drive mode, sensor output voltage is taken at 20 seconds after pressing the switch, just before sensor applied voltage switches from Lo to Hi, and kept as a 'hold value'. This value is updated every time the switch is pressed.

The sensor's sensitivity (ΔV_{OUT}) is calculated from the output in a clean atmosphere ($V_{OUT} [Air]$) and the output in gas ($V_{OUT} [Gas]$) using the following formula:

$$\Delta V_{OUT} = V_{OUT} [Gas] - V_{OUT} [Air]$$

Driving Conditions:

Setting by driving conditions (Jumper pin connections) ○ : Connected — : No connection

Drive mode	JP1	JP2	JP3	JP4	JP5	JP6	Remarks
Continuous drive mode	○	—	○	○	—	—	Initial factory setting
Hi/Lo drive mode	○	—	○	—	○	—	Optional driving condition for evaluation purpose. Please note that the product warranty for TGS1820 sensor is extended to sensor performances in continuous drive mode only.

Note: Please do not change jumper pin positions except for JP4 and JP5.

Continuous drive mode (Default factory setting)



Sensor Operation Mode

- * The green LED lights when the correct input voltage V_{IN} is applied.
- * Constant heater voltage (VH) at 2.3V is applied to the sensor.

Initial Factory Settings and Sensor Applied Voltage

- * A load resistor (RL) is set at 10 Ω with factory setting of a jumper pin to JP1.
- * Factory setting of the sensor applied voltage is 2.3V. It can be changed by adjusting a variable resistor VR1.

Specifications:

Item	Specification
Model No.	EM1820
Product Name	Evaluation module for TGS1820
Applicable sensor	TGS1820
Operating conditions	0~50°C (no condensation)
Output voltage (V_{OUT})	0~2.5V

NOTE:

Please do not adjust VR1 or VR2 unless necessary.

Hi/Lo drive mode (Optional setting)

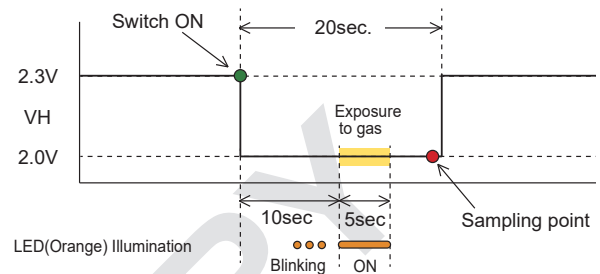

Sensor Operation Mode

- * The green LED lights when the correct input voltage V_{IN} is applied.
- * The Hi voltage at 2.3V is applied to the sensor until a button on this module is pushed to switch to the Lo voltage only once for 20 seconds. After switching to the Lo voltage, an orange LED will blink 3 times within the first 10 seconds just before the time to gas exposure, when the orange LED is on.
- * Expose the sensor to test gas during 5 seconds when the orange LED is on. Then measure the sensor output voltage at the moment just before switching back to the Hi voltage.

The Hi/Lo drive mode is an optional sensor driving condition offered for evaluation purpose.

This sensor drive mode may bring higher selectivity to acetone than using continuous drive mode, depending on design and application of a complete instrument incorporating this sensor.

Initial Factory Settings and Sensor Applied Voltage

- * A load resistor (RL) is set at 10 Ω with factory setting of a jumper pin to JP1.
- * For Hi/Lo drive mode, factory settings of the Hi voltage is 2.3V, and 2.0V for the Lo voltage. They can be changed by adjusting variable resistors; VR1 for Hi voltage, and VR2 for Lo voltage.

FIGARO USA, INC.

121 S. Wilke Rd. Suite 300
Arlington Heights, Illinois 60005
Phone: (847)-832-1701
Fax: (847)-832-1705
email: figarousa@figarosensor.com