

# LPM2610-C13 - pre-calibrated module for LP Gas

### Features:

- \* Factory calibrated
- \* Temperature compensation circuit
- \* Low power consumption sensor TGS2610
- \* Compact size
- \* Meets RoHS regulations

### Applications:

- \* Residential LP gas alarm

The LPM2610 is a pre-calibrated module for LP gas alarms which is precisely calibrated in Figaro's humidity and temperature controlled facility.

The most important process in manufacturing reliable residential gas alarms is adjusting the alarm point. Calibration is a complicated and time consuming process which also requires a substantial investment in calibration equipment. By eliminating the costly calibration process, this module enables users to easily and simply manufacture residential LP gas alarms. Figaro has taken the complexity out of designing a gas detector circuit by providing users with a temperature compensation circuit which combines a built-in thermistor and individually adjusted load resistor together with Figaro's low power LP gas sensor.

A connector allows easy replacement of the module for the purpose of periodic sensor renewal. This input/output connector enables easy installation of the module into the gas detectors' mother board. This same mother board can be used for both methane and LPG gas detectors by simply changing the module.

This module is designed to meet the performance requirements of EN50194 and UL1484.

Please refer to "Technical Information for TGS2610" for sensor sensitivity characteristics. Refer to "Application Notes for TGS2610" for further information regarding circuit design.



### Circuit Diagram

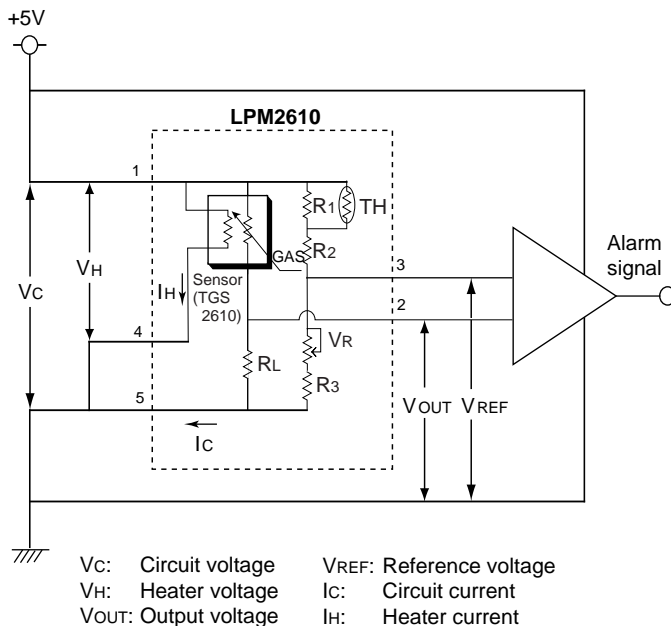

### Basic Pin Connection

A regulated voltage of 5V DC should be applied to Pin #1. A voltage comparator should be connected to Pins #2 and 3. A circuit for detecting breakage of the heater may be connected to Pin #4 (in which case, Pins #4 and 5 should be connected separately to the GND).

When the gas sensor module is exposed to a concentration of target gas which exceeds the desired alarming point, the value of V<sub>out</sub> will reach or exceed the value of V<sub>REF</sub>, causing the module to reach the alarm condition.

NOTE: As described in Sec. 2-6 of "Technical Information for TGS2610", when energizing the sensor after an unpowered period, the sensor's resistance (R<sub>s</sub>) drops sharply for the first few seconds after energizing, regardless of the presence of gases, before recovering to a stable level. This 'initial action' may cause activation of an alarm during the first few moments of energizing since V<sub>RL</sub> would exceed V<sub>ref</sub>. To prevent unnecessary alarms during sensor warmup, a circuit modification such as that shown in Sec. 1-7 of "Application Notes for TGS2610" should be used.

## Parts List:

Symbol	Part	Spec.	Maker	Model #	Qty
R1	Carbon resistor	43kΩ 1/8W	Panasonic	ERJ8GEYJ433A	1
R2	Carbon resistor	1.0Ω 1/8W	Panasonic	ERJ8GEYJ102A	1
R3	Carbon resistor	2.7kΩ 1/8W	Panasonic	ERJ8GEYJ272A	1
RL	Carbon resistor	Var. 1/8W	Panasonic	ERJ8GEYJxxxA	1
V	Potentiometer	10kΩ 1/3W	HDK	NVG6	1
	(alternate)	10kΩ 1/3W	Koa	KVSF689A	1
TH	Thermistor	10kΩ at 25°C B const.=3400±3%	Mitsubishi Materials	SC20-3I103KT	1
	(alternate 1)	10kΩ at 25°C B const.=3370±1%	Mitsubishi Materials	TH11-3H103FT	
	(alternate 2)	10kΩ at 25°C B const.=3414±1%	Semitec	103KT1608T-1P	
	(alternate 3)	10kΩ at 25°C B const.=3380±1%	Murata	NCP18XH103J03RB	
Sensor	Gas Sensor	-	Figaro	TGS2610-C00	1
CN	Connector	-	Nichiatsu	MB5P-90S	1

## Specifications:

Module number		LPM 2610-C13	
Standard test conditions	Test gas conditions	1800±50ppm isobutane in air at 20±2°C, 65±5%RH	
	Circuit conditions	V <sub>H</sub> = 5.0±0.05V DC V <sub>C</sub> = 5.0±0.05V DC	
	Preheating period prior to test	2 days	
Electrical characteristics under standard test conditions	Reference voltage	V <sub>REF(STD)</sub>	V <sub>OUT(STD)</sub> ±0.5V DC
	Output voltage	V <sub>OUT(STD)</sub>	2.5±0.5V DC

## Electrical Characteristics:

Recommended operating conditions	Heater voltage	V <sub>H</sub>	5.0±0.2V DC
	Circuit voltage	V <sub>C</sub>	5.0±0.2V DC
	Minimum impedance between Pin#2 and GND	2.5MΩ	
	Minimum impedance between Pin#3 and GND		
	Operating conditions	0~40°C, 30~95%RH	
	Temperature differential between inside and outside detector casing	≤10°C max. (see NOTE)	
Electrical characteristics under operating conditions	Heater current (current between Pins #1 and 4)	I <sub>H</sub>	56±5mA
	Circuit current (current between Pins #1 and 5)	I <sub>C</sub>	10mA (max.)
	Reference voltage	V <sub>REF</sub>	1.0~4.0V DC
	Output voltage	V <sub>OUT</sub>	0.05~(V <sub>C</sub> -0.05)V DC

**NOTE:** Due to heat generated by circuit components, if the internal temperature of the detector exceeds the environmental temperature outside the detector casing by 10°C or more, the calibrated alarm concentration would drift due to drifting of V<sub>ref</sub>. If users are unable to design detectors so as to keep this temperature differential below 10°C, please consult with Figaro.

## Structure and Dimensions:

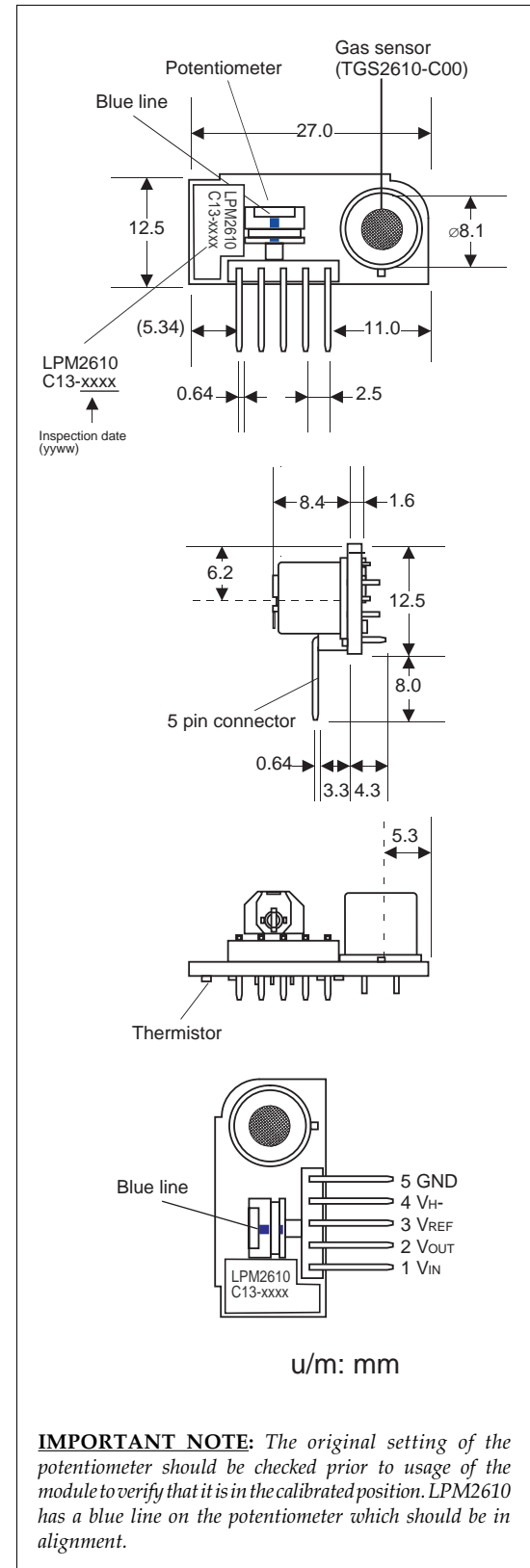

## Expected performance:

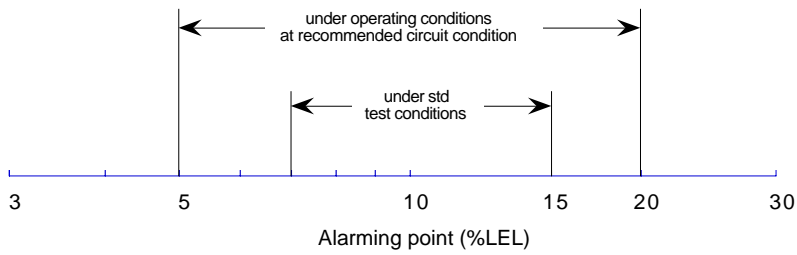

Expected performance of LP gas detectors  
using LPM2610 and 10% LEL alarming point

**NOTE:** When using LPM2610, typical alarm tolerances for 10%LEL of LP gas such as those shown in the figure above can be expected. However, in actual usage, alarm thresholds may vary since the threshold is also affected by such factors as the tolerances of test conditions and heat generation inside the gas detection enclosure. As a result, Figaro neither expressly nor impliedly warrants the performance shown in this figure. If a large difference between the expected and actual performance of detectors is noticed, please consult with Figaro.

## Absolute Maximum Ratings:

Absolute maximum ratings (see NOTE)	Circuit voltage	V <sub>c</sub>	-0.3~+5.5V DC
	Heater voltage	V <sub>H</sub>	-0.3~+5.5V DC (max. of 2 minutes at 5.5V)
	Operating temperature		-15~+55°C (max. 95%RH)
	Storage temperature		-20~+60°C (avoid condensation)
	Soldering temperature		260°C (max. in 10 sec.)

**NOTE:** Detectors should be designed according to "Recommended Operating Conditions" as shown above. However, detector circuits should also be designed not to exceed "Absolute Maximum Ratings" under any circumstances. To exceed these ratings may cause damage or deterioration of the sensor.

*For applications involving usage of LPM2610 for applications other than residential LP gas alarms, please consult with Figaro.*

FIGARO ENGINEERING INC.  
1-5-11 Senba-nishi  
Mino, Osaka 562 JAPAN  
Tel: 81-72-728-2561  
Fax: 81-72-728-0467  
email: figaro@figaro.co.jp  
www.figaro.co.jp